

PM488

Dual Channel 150MSPS, 14-bit DAC PMC

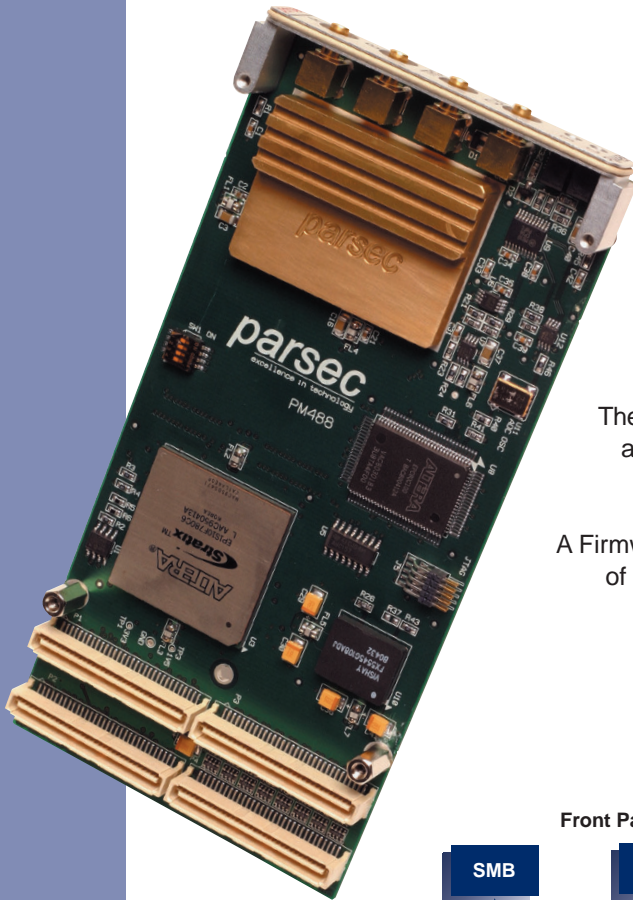

The **PM488** is a dual channel, 150MSPS, 14-bit DAC module conforming to the single PMC form factor. The module generates analogue output signals on the front panel SMB connectors from data it receives via the PCI interface.

The module is set up via the PCI bus. Internal or external trigger signals initiate the analogue signal generation process. The DAC clock is selectable from either an external source or on-board oscillator.

The module's analogue interfaces are situated on the front panel and comprise of the DAC outputs and the external clock and trigger inputs.

A Firmware Development Kit (FDK) supports custom development of FPGA pre-processing functions (e.g. digital up-conversion).

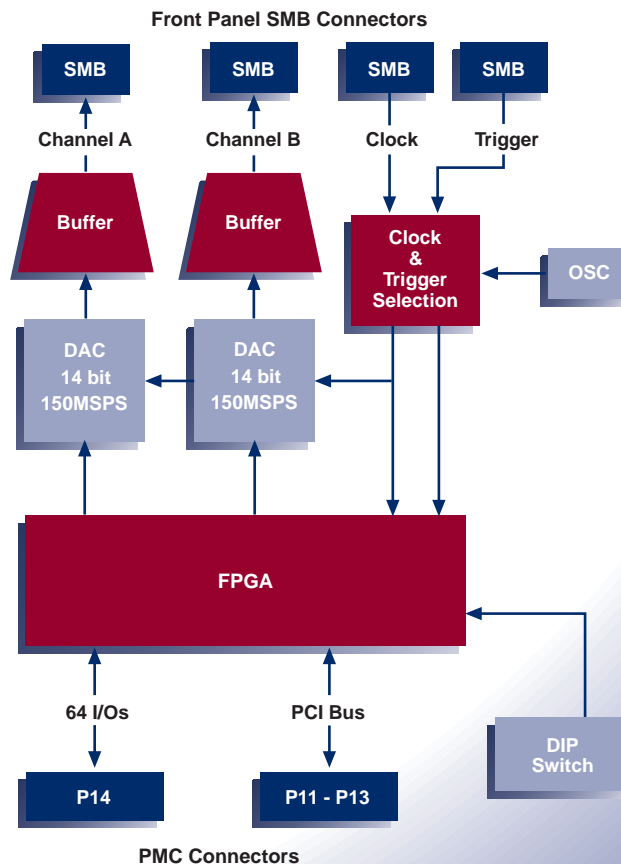

Features

Converter Characteristics

- Analog Devices AD9772A DACs
- SNR: 71dB @ 25.1MHz
- SFDR: 74dBc @ 25MHz
- Sampling resolution: 14-bits

Front Panel Analogue Outputs

- Two single ended AC coupled analogue outputs
- Reconstruction pass band: 67.5MHz
- Full-scale output power: -2dBm (0.5Vp-p)
- Output Impedance: 50 Ohm

Front Panel SMB Clock Input

- Single ended AC coupled LVPECL input
- Frequency Range: 200kHz - 150MHz
- Input Voltage: sine or square wave (1Vp-p)
- Input Impedance: 50 Ohm

Front Panel SMB Trigger Input

- Single ended DC coupled LVPECL input
- Input Impedance: 50 Ohm

PCI Interface

- 32/64-bit 33/66MHz 3.3V PCI bus in ALTERA Stratix® FPGA
- Peak PCI data rate (533Mbytes/s) supported

Buffering

- 16k samples per channel (standard) to 64k samples per channel

Software Support

- Device driver for Windows 2000/XP and Linux
- Device driver API documentation and sample source code
- Matlab API via Mex DLL file
- Test / demonstration application
- Application / driver development services available on request

Firmware Support

- FDK available for custom firmware development
- Firmware development services available on request

Application Examples

- Baseband or IF waveform reconstruction
- Radar and Sonar
- Instrumentation
- Wireless base stations
- Software-defined radio

Ordering Information

PM488 - X - Y - Z
X: On-board oscillator frequency (105MHz standard)
Y: Buffer size (16k, 32k or 64k)
Z: FPGA EP1S (10, 25 or 30)
(Standard order code: PM488 - 105 - 16k - 10)



OUR *Purpose*

to enhance the
competiveness
of our clients

Disclaimer: The information contained in this product brief is believed to be accurate; however, no responsibility is assumed by Parsec for its use, and no license or rights are granted by implication or otherwise in connection therewith. Specifications are subject to change without notice.

Stratix® is a registered trademark of Altera Corporation



Buildings 9 & 10 • Manhattan Office Park • 16 Pieter Street
Highveld Techno Park • Centurion • 0157 • South Africa
PO Box 67499 • Highveld • 0169 • South Africa
Tel: +27 12 678 9740 • Fax: +27 12 678 9741
email: info@parsec.co.za • www.parsec.co.za